

PLAYGROUND MAINTENANCE

Introduction

Because use and environmental factors as well as materials vary, every playground is different. It is imperative that those responsible for maintenance of the playground understand the maintenance requirements necessary to keep it safe, attractive and to extend its useful life. It is the responsibility of the playground equipment manufacturer to provide instruction as to how the equipment is to be installed and maintained as well as to provide a general guideline as to the frequency of those procedures. It is your responsibility as owner to establish a frequency schedule for each playground and to follow the manufacturers recommended procedures. Landscape Structures' "A Guide to the Frequency of Inspections" will be helpful but not the only criteria in establishing your frequency schedule.

The accompanying inspection report has been computer generated for your specific playground. Keep one set of sheets as your original to make additional copies as needed. Fill in the park name, inspectors name, date, time and inspection schedule (Inspection: 3 of 1996). The inspection report identifies the major components of your structure that can be keyed to the accompanying plan. A column also indicates how often the procedure should be performed (2 indicates that procedure must be performed at every second inspection, 10 every tenth inspection, etc.) and another indicates what your findings were. The procedures manual shows how to perform the procedure and how your findings should be recorded. The last space is also used to identify any action you have taken or that will be taken on or before your next inspection. Once you have become familiar with the maintenance procedures and how to record your findings, the inspection report is the only sheet you will need for your inspection. An example of a completed report is shown on the back of this sheet. If you need additional space to report your findings or action taken, use the back of the same sheet. Once your inspection is complete and all necessary action taken, file your report in the back of this binder.

Protective surfacing throughout the fall zone must be maintained at a thickness or depth sufficient to meet ASTM F1292 standards (Standard Specification for Impact Attenuation of Surface Systems Under and Around Playground Equipment) at maximum fall heights for equipment installed above the

surfacing. If you have not purchased your protective surfacing from Landscape Structures, we have made the assumption that you will be using a loose material such as sand or wood chips as your impact absorbing system. To keep it in conformance with the ASTM standards, this type of material requires substantially more maintenance than a molded synthetic surface system. Organic materials can absorb moisture, compact and decompose all of which will reduce the effectiveness of the system. The inspection report shows expected operations and their frequencies for common materials. Your specific material may vary. The edger retaining this material must not cause a trip hazard - it should be obvious and visible.

So that the same format can be kept for all products within the playground, space has been left on the inspection report where additional products can be added. When adding products, make sure you keep the same type of records as have been suggested herein.

It is important that you recognize the severity of the potential hazard that may be found upon inspection. In some cases, you may have to close the playground until repairs are made. These hazards will most likely be the result of vandalism - assuming proper maintenance has been performed.

The owner has the responsibility to certify/qualify those performing installation and maintenance services. This can be done by attending a Landscape Structures maintenance seminar and/or by attending various industry association meetings on the subject.

If replacement parts are required, they can be ordered from your local Landscape Structures representative or the factory. Part numbers and descriptions can be found on the back of the installation instruction sheets provided in this binder.

**POOR
MAINTENANCE
IS
THE**

**MAJOR
CAUSE
OF
AT
LEAST
A THIRD
OF
ALL
REPORTED
PLAYGROUND
ACCIDENTS**

Reading The Maintenance Procedures Sheets

Indicates the frequency that these items should be inspected, i.e.: 1 indicates inspection everytime, 10 indicates every tenth inspection. These numbers are repeated on the inspection report.

Indicates the part to be inspected and how to do it. The part is repeated on the inspection report.

PLAYGROUND MAINTENANCE

Fasteners/Hardware 1
If rusty - use wire brush and paint with zinc-rich paint. Replace if pitted from rust or deformed. Tighten attachment hardware.

Caps 1
Replace cap if missing or damaged beyond repair. Make sure attachment rivets are secure. Repair damaged powdercoating per instructions.

Posts/Flanges 1
Replace post if post or flange is severely damaged or pitted with rust (Area at the top of the footing is most vulnerable). Repair damaged powdercoating per instructions. Posts must be plumb.

Concrete Footings 10
Shovel away protective surfacing and part of subsoil to inspect. Replace footing if it is cracked or not tight around post or subsoil. Add protective surfacing if footing is not covered with at least 10" of material.

PlayShaper System

Common Parts and Procedures

PlayShaper
Document # 115495-01
6-20-96

Title of sheet.
Common terminology corresponding to installation instructions.

Drawing of typical details or full component.

10" Minimum, typical depth of loose protective surfacing, your depth may vary..

Sheet #

Completing The Inspection Report

Title of procedures sheet.

Part to be inspected. Repeated from procedures sheet.

Frequency of inspection. Repeated from procedures sheet (i.e. every inspection in this case).

3-hole punched so all documents can be kept in binder.

There are additional pages of this report form for this structure.

LANDSCAPE STRUCTURES INC
Delano, Mn 1-800-328-0035

INSTALLATION ADDRESS - JOB NUMBER S00000

Bigalke Park
12199 15th Street SW
Delano, MN 55328
USA

Inspection Report

Today's Date 9-30-96

Inspection# 6 of 96 Your

Time 9:15 In 11:00 Out

John Smith
Inspector

GENERAL MAINTENANCE SHEETS

INTRODUCTION _____

CLEANING INSTRUCTIONS _____

REPAIR OF POWDERCOATING _____

COMPONENT MAINTENANCE SHEETS

DESCRIPTION	FREQ.	FINDINGS/ACTIONS TAKEN
PG MAINT PLAYSHAPER SYST		
FASTENERS/HARDWARE	1	Tightened
CAPS	1	OK
POSTS/FLANGES	1	Some chipped paint, touched up
CONCRETE FOOTING(S)	10	NA
PG MAINT WHEEL		
FASTENERS/HARDWARE	1	Tightened loose bolt
WHEEL	1	OK
PERMALINE PANEL	1	OK
BOLT CAPS	1	OK
GENERAL PERM PANELS		
FASTENERS/HARDWARE	1	Tightened
PERMALINE PANEL	1	Burnished out deep scratch
WHEEL	1	OK
GENERAL PERM PANELS		
FASTENERS/HARDWARE	1	Tightened
PERMALINE PANEL	1	OK
WHEEL	1	Patched gouge with repair kit
SPELLING PANEL		
FASTENERS/HARDWARE	1	OK
PERMALINE PANEL	1	Burnished out some scratches
DISKS	1	OK
SHAFT	1	OK

CONTINUED...

Keep one copy of this form as your original to make copies as necessary.

Indicates the sixth time the playground has been inspected in 1996.

Accumulate for planning and budgeting purposes. Used to assess the life costs of equipment.

What did you find and what you did about it. Not a check mark, but a descriptive answer.

Not inspected this time.

PLAYGROUND MAINTENANCE

It is estimated that at least 40% of all accidents on public playgrounds could have been prevented if a good preventative maintenance program were in place. A good program establishes a frequency of inspections that are commensurate with the use and environmental factors unique to each play area. Some playgrounds will require daily inspections while others in the same area may require only bi-weekly inspections. The deterioration and/or wear of various play components can be predicted when certain factors are known. On the other hand, vandalism has a major influence on the frequency of inspections but is not as predictable.

The following guide utilizes the most common use and environmental factors that will influence your schedule. Each factor has been weighed as to its importance and influence on the schedule. Local conditions may include other factors, and in some cases, may affect seasonal adjustments to the schedule. Experience is your best guide.

A Guide to the Frequency of Inspections

Enter the factor points in the right hand column that best describes the conditions at the playground.

Use Factors	Factor Points
Vandalism	_____
High - 10 pts.	
Moderate - 5 pts.	
Low - 2 pts.	
Use	_____
High - 10 pts.	
Moderate - 2 pts.	
Low - 2 pts.	
Age	_____
PreSchool - 1 pt.	
School Age - 3 pts.	
All Ages - 2 pts.	

Materials

Protective Surfacing	_____
Loose Material - 18 pts.	
Unitary Material - 2 pts.	
Material of Major Components	_____
Wood, Painted Steel - 4 pts.	
Plastics, Aluminum, Galvanized Steel - 2 pts.	
Stainless Steel - 0 pts.	
Equipment	_____
Moving: Swings, Spin-Arounds, etc. - 8 pts.	
Static: Non-Moving Climbers - 2 pts.	
Both - 8 pts.	
Age of Equipment	_____
0-5 years - 2 pts.	
5-10 years - 6 pts.	
Over 10 years - 10 pts.	

Environmental Factors

Salt Air - Coastal Exposure	_____
None - 0 pts.	
Moderate - 2 pts.	
High - 5 pts.	
Acid Soils/ Rain	_____
None - 0 pts.	
Moderate - 1 pt.	
High - 2 pts.	
Sun Exposure	_____
Low - 1 pt.	
Moderate - 2 pts.	
High - 4 pts.	

Total

Enter Total Points Here _____
 See back to determine frequency of inspections.

PLAYGROUND MAINTENANCE

Your Total Points

50 or More
40-50
30-40
Below 30

Recommended Frequency of Inspections

Daily Inspections	High Frequency
Weekly Inspections	
BiMonthly Inspections	Low Frequency
Monthly Inspections	

NOTE:

For your program to be effective, the inspectors must be properly trained. Call the equipment manufacturer if you are uncertain as to how a particular component should be inspected and when it should be replaced.

Keep this worksheet with other documentation on this playground.

Date

Person Completing Worksheet

Name/Address of Playground

Recommended Frequency of Inspections:

High Use Period

Low Use Period

PLAYGROUND MAINTENANCE

Graffiti cleaner will work on most surfaces. Follow the directions on the bottle.

Generally speaking, the longer the stain has been on a product the harder it is to remove.

■ Permalene/Poly Parts

Cleaning Instructions

Prior to applying graffiti cleaner to affected area, test cleaner in an inconspicuous location to verify it will not damage the surface/coating.

Apply graffiti cleaner to affected area. Follow the directions on the bottle.

■ TenderTuff Coated Parts

Apply graffiti cleaner to affected area. Follow the directions on the bottle.

Heavy stains may need to be removed mechanically first (scrape with a knife or sandpaper).

Seal the affected area with "Clear Guard" by Turtle Wax or "Armor All" by Armor All. Buff the area until the colors blend.

■ Powdercoated/Digifuse Parts

Apply graffiti cleaner to affected area. Follow the directions on the bottle.

■ Clear Bubbles/Windows

CAUTION: Do not use graffiti cleaner on bubbles or windows. Use any readily available glass cleaner.

■ Wood Parts

Because of the porosity of wood, most stains will require mechanical removal. Scrape the affected area with a knife or sandpaper. This process will change the appearance of the affected area. In time the area will blend with the surrounding material.

To eliminate minor stains and keep the wood its natural color and even reduce some cracking, apply two heavy coats of a clear non-toxic water repellent. This process will have to be repeated as necessary to retain the color.

To permanently color the wood, apply a non-toxic water repellent colored stain. This process will have to be repeated as necessary to retain the color.

PLAYGROUND MAINTENANCE

■ Belt

Cleaning Instructions

A black gummy texture may form in high foot traffic areas of belting. To remove, use either a heavy duty citrus degreaser or a liquid based graffiti cleaner found at most hardware stores. Examples include Zep Heavy-Duty Citrus Degreaser and Motsenbocker's Lift Off 4. Other graffiti removers may be successful at removing the black gummy surface, but they should first be tested in an inconspicuous location. Do not let cleaners sit too long on the belting as they may attack the PVC. When done cleaning, wash the belting to remove any excess cleaners. Note that graffiti cleaner is not the best solution for cleaning.

If belting has been vandalized with graffiti, apply the graffiti cleaner per the directions on the bottle. If the graffiti has absorbed into the belting as may happen from some permanent markers, then clean off any remaining graffiti cleaner and sand the surface using a medium grit sand paper.

PLAYGROUND MAINTENANCE

Repair of Powdercoating

Equipment Required:
Maintenance Repair Kit

■ A

With emery cloth, sand area to be repaired until all rust is removed. Be sure to rough and feather edges of surrounding powder coated area with 400 grit sandpaper until smooth.

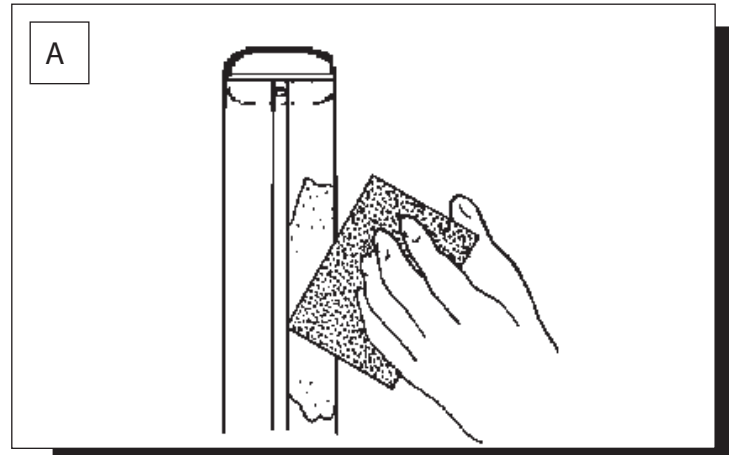

■ B

To help assure best results be sure areas to be painted are clean and dry. This can be accomplished by using a cloth dampened with rubbing (isopropyl) alcohol or water.

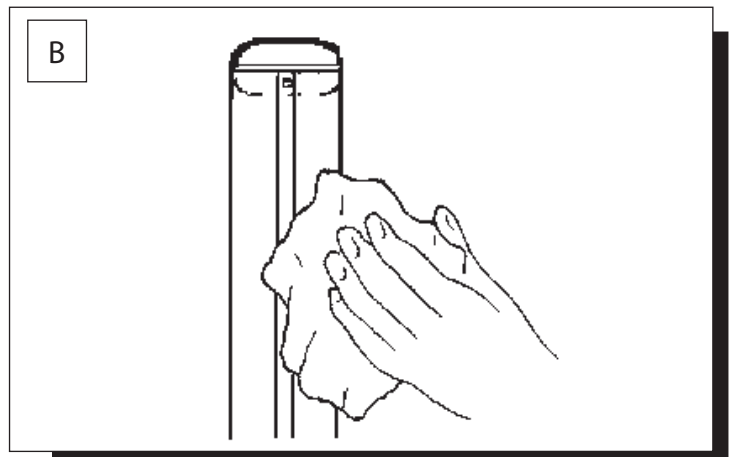

■ C

Protect adjacent areas from overspray, if necessary. Apply a minimum of 3 light coats of primer (supplied). Allow to dry 'to the touch' between coats. Lightly sand with 400 grit sandpaper, then wipe with clean cloth. Use same method to apply a minimum of 3 light coats of paint. Be sure to allow areas to dry 3 to 4 hours before use. (Drying time will vary)

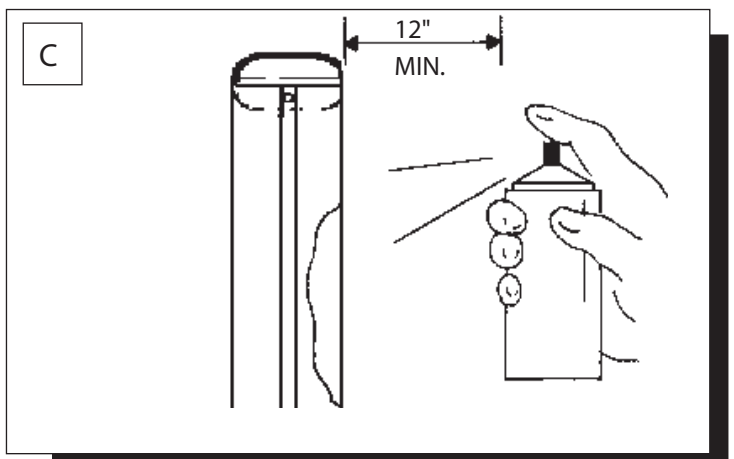

NOTE: Be sure to hold spray can 12" - 14" from surface.



Delano, MN 800-328-0035

Inspection Report

Location _____ Inspector _____

Date _____ Time _____ Frequency of Inspections _____

Installation Date _____ Installer _____

PRODUCT:

No Action	_____
Cleaned	_____
Repaired	_____
Replaced	_____
Notes	_____

PRODUCT:

No Action	_____
Cleaned	_____
Repaired	_____
Replaced	_____
Notes	_____

PRODUCT:

No Action	_____
Cleaned	_____
Repaired	_____
Replaced	_____
Notes	_____

PRODUCT:

No Action	_____
Cleaned	_____
Repaired	_____
Replaced	_____
Notes	_____

PRODUCT:

No Action	_____
Cleaned	_____
Repaired	_____
Replaced	_____
Notes	_____
